

**MICROSEPARATOR® HC3 Coolant Cleaning System**

Automated coolant cleaning system for up to three generators, organic materials only. Integrates with Pump Stations, Chip Separators, or Compactor Assemblies. Designed for operation remote from generators allowing optimum use of surfacing laboratory space.

**Includes:**

- Model CF105G Self-Cleaning Centrifuge with platform and sludge cart
- PLC system electrical control panel
- 304SS Coolant Tank
- Generator supply pump
- Centrifuge supply pump
- Refrigeration coil
- Tank floor agitation system
- Automatic level controls
- Automatic water makeup system, coolant metering system



**System Dimensions**

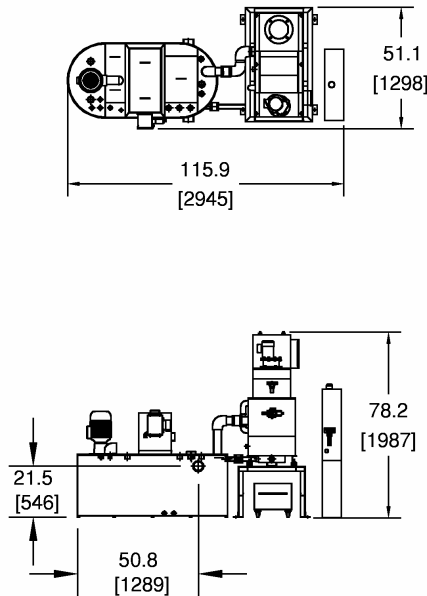

**Utility Requirements**

**Microseparator® HC3**

**Power:**

208V, 27A, 60 HZ, 3 phase  
400V, 15A, 50 HZ, 3 phase

**Compressed Air:**

60 PSI @ 1 SCFM  
4.2 bar @ 28 l/m

**Domestic Water:**

60 psi  
4.2 bar