

PUMP STATION Lens debris and fluid pumping system

Pump Station is used with Microseparator®, HC3, or HC6 systems. All fluid and lens debris is pumped from the generator overhead via plastic pipe to the remote Chip Separator or Compactor Assembly. Compatible with all organic milling debris and all organic finishing debris.

Working Range: One generator

Includes

- Stainless steel pump and housing
- Fabricated steel enclosure with lens retrieval access cover
- PLC control panel
- Automatic level control system
- Automatic valve for supply pipeline
- Automatic valve for discharge pipeline



Dimensions

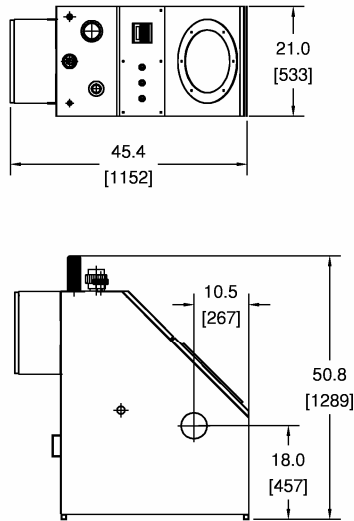

Utility Requirements

Pump Station

Power:
208VAC, 7A, 60 HZ, 3 phase
400VDC, 4A, 50 HZ, 3 phase

Compressed Air:
60 PSI @ 1 SCFM
4.2 bar @ 28 l/m