



The CF105-MS2 Microseparator® is a fully automated, self-cleaning liquid-solid separator for efficient treatment of process water, coolants, and oils.

Key Advantages

- Handles abrasive materials including glass, quartz, ceramics, carbide, and metals
- Robust construction ensures long service life and minimal downtime
- Improves fluid quality, extending equipment life and reducing operating costs

Self Cleaning Operation

- Automatic solids discharge into drum or collection bin with no manual handling required
- Continuous self-cleaning operation minimizes operator intervention
- Programmable cleaning cycles via PLC to match specific process conditions

Flexible System Options

- Easily integrates into existing fluid processing systems
- Available as part of a complete, engineered system tailored to your process
- Customizable configurations to meet performance, capacity, and automation needs

Mounting Stand

48" stainless steel mounting stand

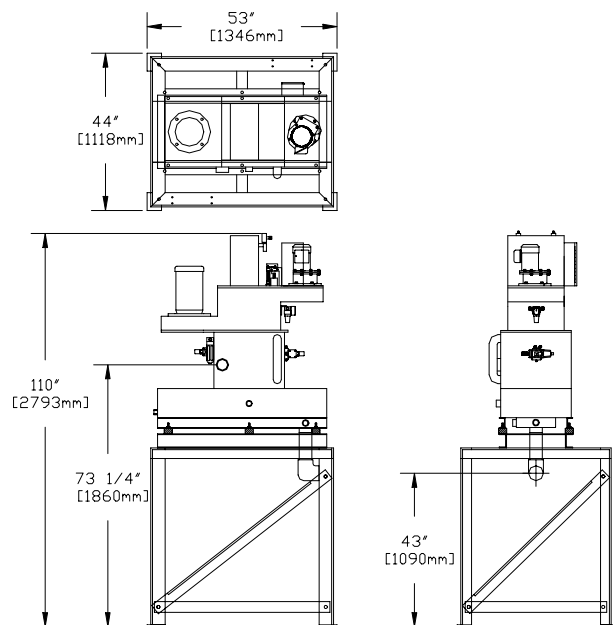

Technical Data

Materials of Construction

- 304 SS enclosure
- Aluminum rotor and carbon steel scraper
- Cast iron bearing housing
- Optional 304 SS rotor assembly

Process Capacity

- Flow rate: 25 gpm (95 lpm)
- Rotor volume: 3.75 gal (14.2 l)

Electrical

- 3 hp (2.2 kw) drive motor
- .5 HP (.4 kw) gear motor
- Allen-Bradley PLC system electrical controls
- UL 508 A construction CE/CSA std available
- Pump motor starter included
- All 3 phase power configurations available

Options & Accessories

- 304 SS rotor, scraper, and bearing housing
- Customization of PLC system controls
- Feed pump per process requirements
- Complete fluid processing systems (tank, pumps, etc)
- CE Mark available on request

microseparator®

Precision Separation, Superior Filtration

© 2026 Bazell Technologies Corporation. All rights reserved. Bazell Technologies® and, Microseparator®, are registered trademarks of Bazell Technologies Corporation.

☎ +1 972.677.2700

✉ cs.na@dacvision.com

🌐 www.bazell.com