



The CF50-MS2 Microseparator® is a manually cleaned liquid-solid centrifuge designed for reliable removal of abrasive solids from process water, machine tool coolants, and oils in demanding industrial applications.

### Key Advantages

- Efficient centrifugal separation of solids
- Handles abrasive materials such as glass, quartz, ceramics, carbide, and metals
- Rugged, industrial-duty construction
- Manual cleaning with minimal downtime

### Simple Cleaning

- Solids collect in a reusable liner inside the rotor
- Cleaning requires stopping the unit, opening the hinged cover, and removing solids
- No disposable filter media

### Flexible System Options

- Ideal for customer-designed systems or skids
- Integration and application support available
- Skid modules and tank systems offered with CF50 or higher-capacity CF80 series centrifuge

### Mounting Stand 2

Stainless Steel Mounting Stand (47" Inlet/Outlet Height)

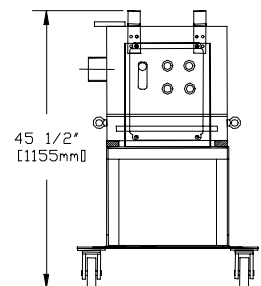
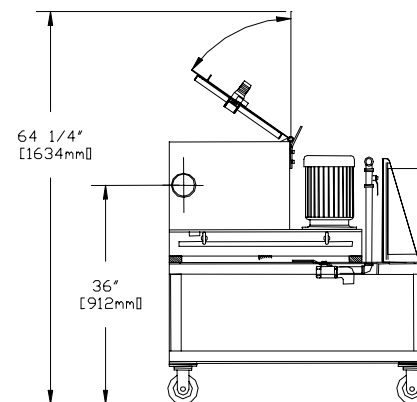
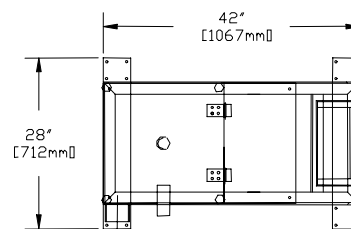

## Technical Data

### Materials of Construction

- 304 SS enclosure
- Aluminum rotor assembly optional 304 SS
- Neoprene liner

### Process Capacity

- Flow rate: 12 gpm (45 lpm)
- Rotor volume: 1.75 gal (6.6 l)

### Electrical

- 2 hp (1.5 kw) drive motor
- 110v cover limit switch or optional 24V DC electro-mechanical interlock

## Options & Accessories

- Electrical control panel including spare motor starter
- Feed pump (per process requirements)
- Spare rotor liner
- 304 SS rotor assembly
- CE Mark available on request